

EKHO

INFRASTRUCTURE
SOLUTIONS

Durisol



PRECAST ACOUSTIC FACINGS

Acoustic facing tiles for a modular noise absorption solution that addresses a range of noise mitigation requirements.

Durisol precast acoustic facing tiles provide a modular noise absorption solution for a wide variety of acoustic applications. From noisy loading dock areas to courtyards or other parallel building zones, the tiles offer complete versatility in that they can be attached to any existing flat wall surface, making them ideal for retrofit applications as well as new construction.



WHAT IS DURISOL®

Durisol® is the pioneer of absorptive noise wall products.

A proprietary name for the durable, lightweight and cementitious/wood composition product utilized in acoustic panels to achieve ultimate noise absorption in engineered noise barrier systems.

The mix is made of chemically neutralized and mineralized organic softwood shavings which are processed to an acoustically engineered size and are bonded together under pressure with Portland Limestone Cement (PLC).

Durisol acoustic facings are:

- Self-draining and thoroughly tested for resistance to weather exposure including freeze-thaw, road de-icing chemicals, combustibility, and fungicides.
- Cast in National Precast Concrete Association (NPCA), CSA certified precast concrete plant.

FEATURES & BENEFITS

- Lightweight & versatile
- Noise absorption
- Thermally insulating
- Modular design
- Easy installation
- Custom colours & finishes

TYPICAL APPLICATIONS

- Commercial & Industrial Buildings
- Retrofit Applications
- Loading Areas
- Shooting Ranges
- Railways
- Grade Separations

PANEL DETAILS

Typical application showing standard size: 600x900mm panel

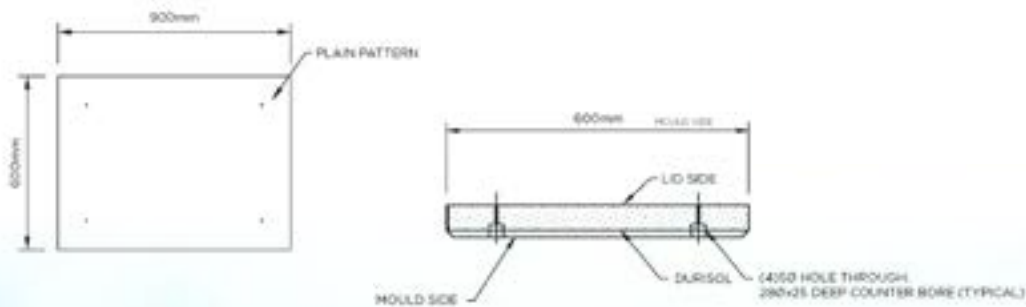

STANDARD COLOURS

The Precast Acoustic Facings System is available in the same range of existing Durisol standard colours and finishes.



This palette serves as a guide only; Durisol's real-life texture will offer a variance in colour. Colour appearance also varies depending on time-of-day, light reflectance, etc.



Custom colours and finishes are available.



Durisol.

PRECAST ACOUSTIC FACINGS

EKHO

INFRASTRUCTURE
SOLUTIONS

Canada: 45 Frid Sreet, Suite 1, Hamilton, ON L8P 4M3

U.S.A.: 10 Campus Boulevard, Newtown Square, Pennsylvania, 19073

email@ekhois.com

ekhois.com



NPCA



QF108176-1 Member