

EKHO

INFRASTRUCTURE
SOLUTIONS

**International
Fence**



ACOUSTICAL FENCE SOLUTIONS

Pre-designed, community-inspired precast noise solutions offering project-ready convenience.

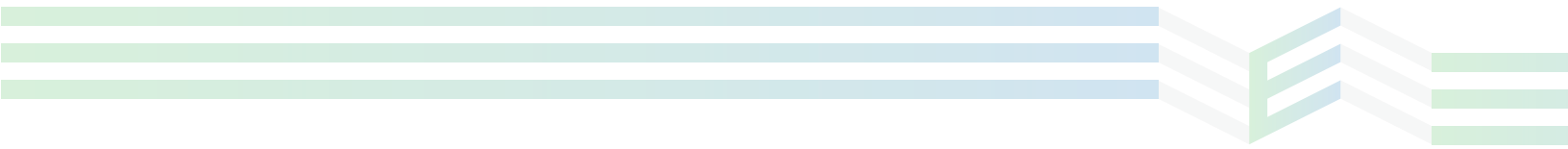

DESIGN AND ENGINEERING SERVICES FROM CONCEPT TO COMPLETION



International
Fence



International Fence is a brand known and recognized across Ontario cities and towns. Its simple pattern and straightforward design make it an easy fence to install and maintain. A smarter alternative to wood or other materials that quickly deteriorate, this precast system provides years of service life, consistent quality, and is pre-designed to be project ready.

WHY US?

EKHO Infrastructure Solutions is where proven design, quality standards and operational efficiency come together to produce on-demand, specialty precast and turnkey project service.



BUILT TO LAST.

We specialize in providing a quality, precast concrete fence system that is manufactured and held to the highest industry standards.



READY TODAY.

We understand the importance of quick and timely delivery, which is why we maintain in-stock inventory of panels ready to ship to your jobsite.





ACOUSTICAL FENCE. INTERNATIONAL FENCE.

Renowned for its clean, repeatable design, International Fence offers an easy-to-install and low maintenance acoustic solution.

DURABILITY OVER DECAY

A smarter alternative to wood or other fence materials that quickly deteriorate.

ENGINEERED FOR EXCELLENCE

Our system provides years of service life, consistent quality, and is pre-designed to be project ready.

TIMELESS SIMPLICITY

Maintains the same look for years to come and adds a new level of privacy homeowners can appreciate.

OUR CANADIAN STANDARDS

- CAN/CSA A23.1-04/A23.2 – Concrete Materials and Methods of Concrete Construction/ Methods of Test and Standard Practices for Concrete
- CAN/CSA A23.4 Precast Concrete
- CAN/CSA G164-M92 (R2003) – Hot Dip Galvanizing of Irregularly Shaped Articles
- CSA G40.20-13/G40.21-13 – General Requirements for Rolled or Welded Structural Quality Steel/Structural Quality Steel
- CSA S16-09 – Design of Steel Structures
- Ontario Building Code (OBC)
- Canadian Highway Building Design Code (CHBDC)





MINIMUM
25-YEAR
SERVICE LIFE



30+
YEARS STRONG



PRE-ENGINEERED
FENCING
SYSTEM

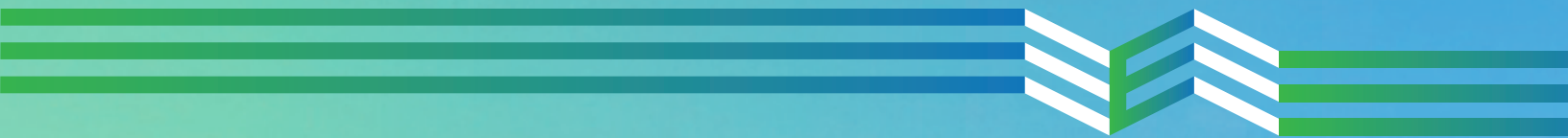

WALL COMPONENTS AND INTEGRATION

International Fence offers versatile noise wall solutions with impressive height and integrated retaining options. Patterns and colours can be tailored for specialized projects.



WALL SPECIFICATIONS

Wall Heights	2m height (up to 5.5m)
Standard Post Spacings	4910mm c/c
Panel Thickness	120mm
Meets Minimum Mass Required	20kg/m ²
Sound Transmission Class	32

International
Fence

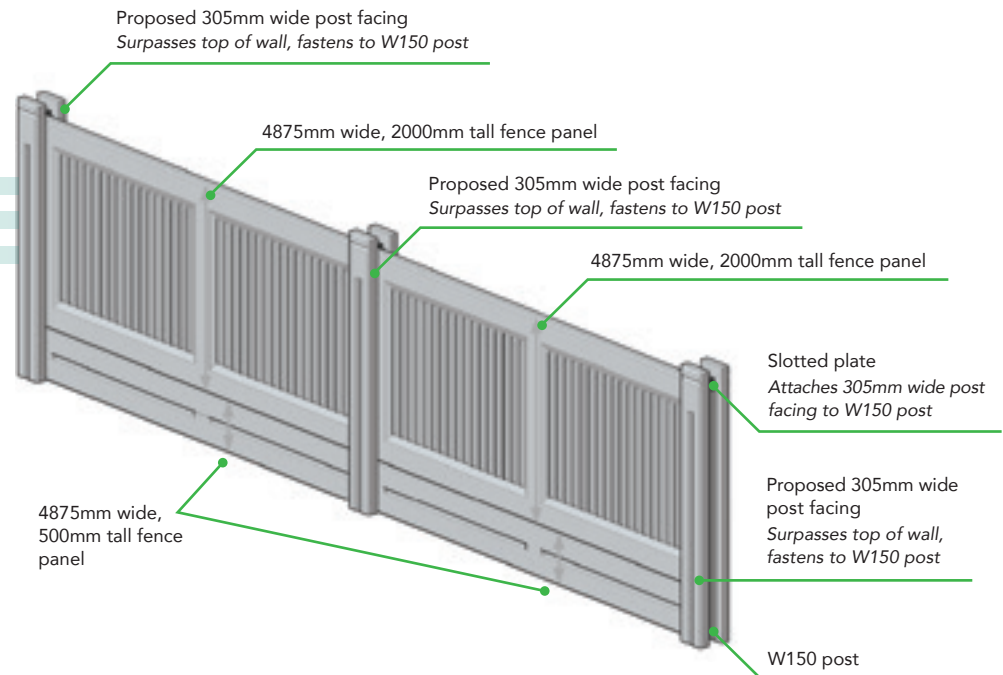

EKHO

INFRASTRUCTURE
SOLUTIONS



Simplified precast concrete wall system.



Easy installation with minimal property disturbance.



Pre-Engineered & available on demand.



Safer, more secure fencing option.



0.5M FENCE PANEL

Panel Dimensions (LxH)	4875 x 500mm
Panel Thickness	127mm
Approximate Panel Weight	568kg (1250lbs)

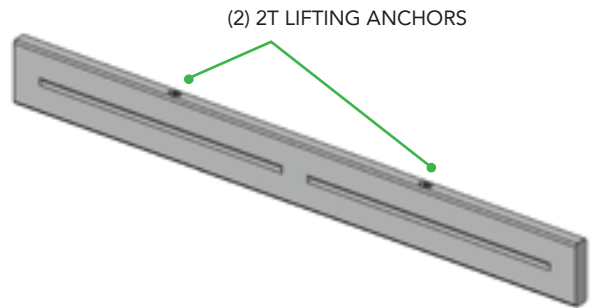

1M FENCE PANEL

Panel Dimensions (LxH)	4875 x 1000mm
Panel Thickness	127mm
Approximate Panel Weight	1136kg (2500lbs)

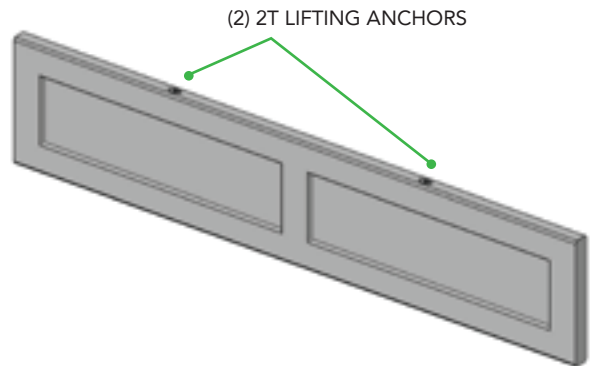

2M FENCE PANEL

Panel Dimensions (LxH)	4875 x 2000mm
Panel Thickness	127mm
Approximate Panel Weight	2727kg (5000lbs)

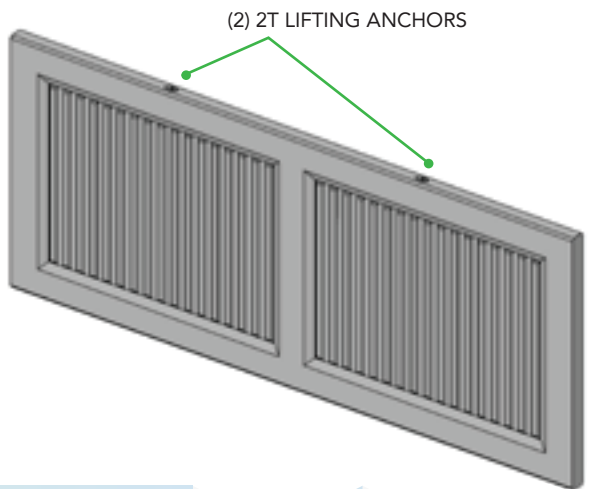

ACOUSTICAL FENCE SOLUTIONS

EKHO

INFRASTRUCTURE
SOLUTIONS

45 Frid St, Suite 1, Hamilton, ON L8P 4M3
email@ekhois.com

ekhois.com

MADE IN



NPCA



QF108176-1 Member

